

21 March 1984

(Supersedes LO 5-3820-233-1211-1, -12/1-2, and -12/1-3, 8 AUGUST 1969)

**CRUSHER, JAW, DIESEL ENGINE DRIVEN,
SEMITRAILER MTD; 35-TON PER HOUR CAPACITY
(IOWA MANUFACTURING CO., MODEL 2A-2A)
(NSN 3820-00-851-6728) COMPONENT OF CRUSHING
AND SCREENING PLANT, DIESEL ENGINE DRIVEN
(3820-00-878-4285)**

Reference: TM 5-3820-233-12/1 and FEDERAL SUPPLY CATALOG C9100-IL.

Intervals (on-condition or hard time) and the related man-hour times are based on normal operation. The man-hour time specified is the time you need to do all the services prescribed for a particular interval. On condition (OC) oil sample intervals shall be applied unless changed by the Army Oil Analysis Program (AOAP) laboratory. Change the hard time interval if your lubricants are contaminated or if you are operating the equipment under adverse operating conditions, including longer-than-usual operating hours. The hard time interval may be extended during periods of low activity. If extended, adequate preservation precautions must be taken. Hard time Intervals will be applied in the event AOAP laboratory support is not available.

WARNING

Dry cleaning fluid is flammable. Do not use near a flame or excessive heat. Use only with adequate ventilation. Avoid prolonged breathing of vapors and minimize skin contact.

Clean parts or fittings with dry cleaning solvent (SD), Type II or equivalent. Dry before lubricating. Dotted arrow shafts indicate lubrication on both sides of equipment. A dotted circle indicates a drain below. Relubricate all items found contaminated after fording or washing.

The lowest level of maintenance authorized to lubricate a point is indicated by one of the following symbols as appropriate: Operator/Crew (C); and Organizational Maintenance (O).

Reporting errors and recommending improvements. You can help improve this manual. If you find any mistakes, or if you know of a way to improve the procedures, please let us know. Mail your letter or DA Form 2028 (Recommended Changes to Publications and Blank Forms) direct to: Commander, US Army Tank-Automotive Command, ATTN: DRSTA-MB, Warren, MI 48090. A reply will be furnished to you

*The time specified is the time required to perform all services at the particular interval (on-condition or hard times).

***TOTAL MAN-HOURS**

INTERVAL	MAN-HOURS
10	0.5
50	0.5
100	2.0

***TOTAL MAN-HOURS**

INTERVAL	MAN-HOURS
250	0.5
500	0.7
1000	2.5

TA 220076

LUBRICANT • INTERVAL

INTERVAL • LUBRICANT

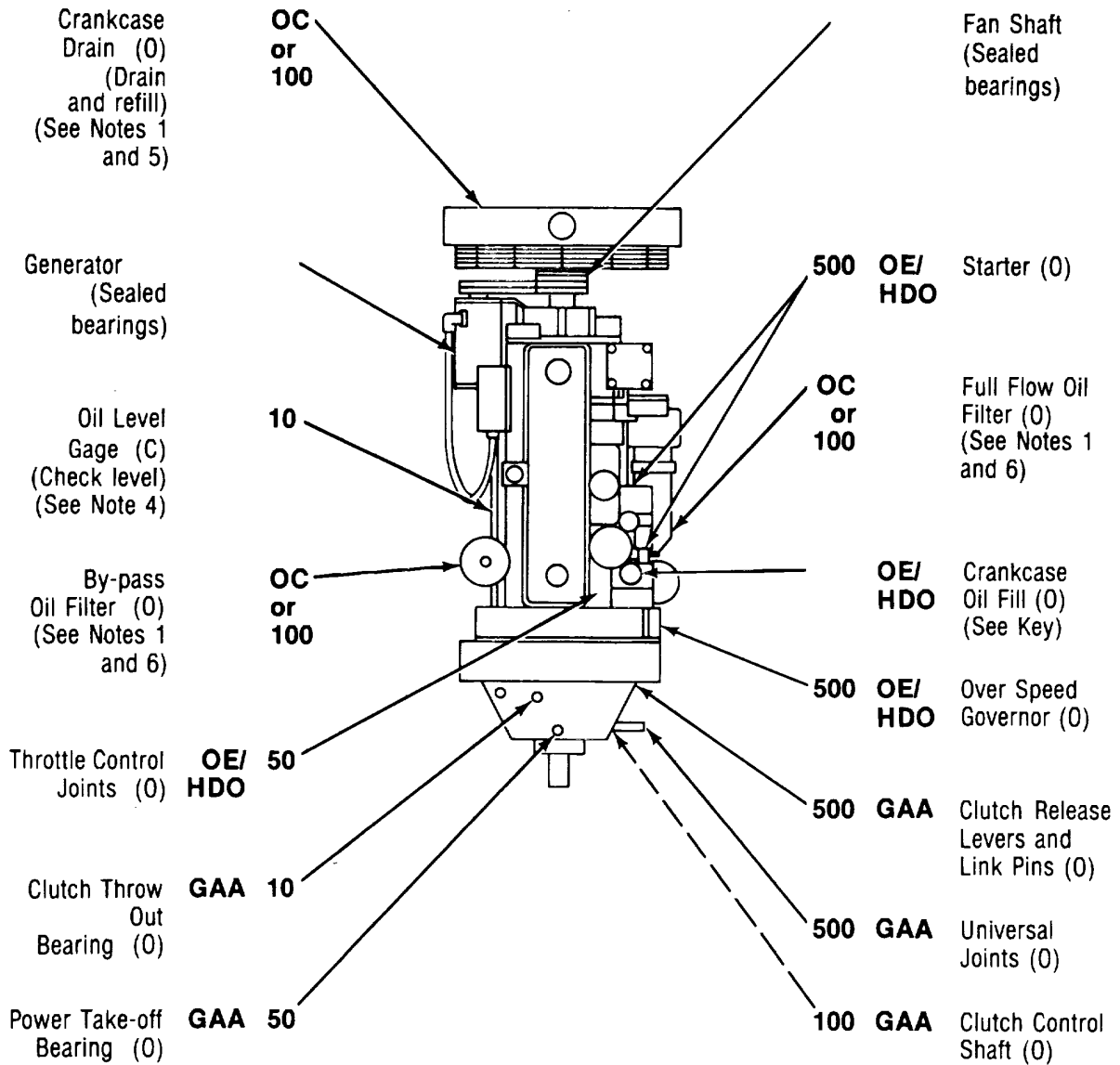

LUBRICANT • INTERVAL

INTERVAL • LUBRICANT

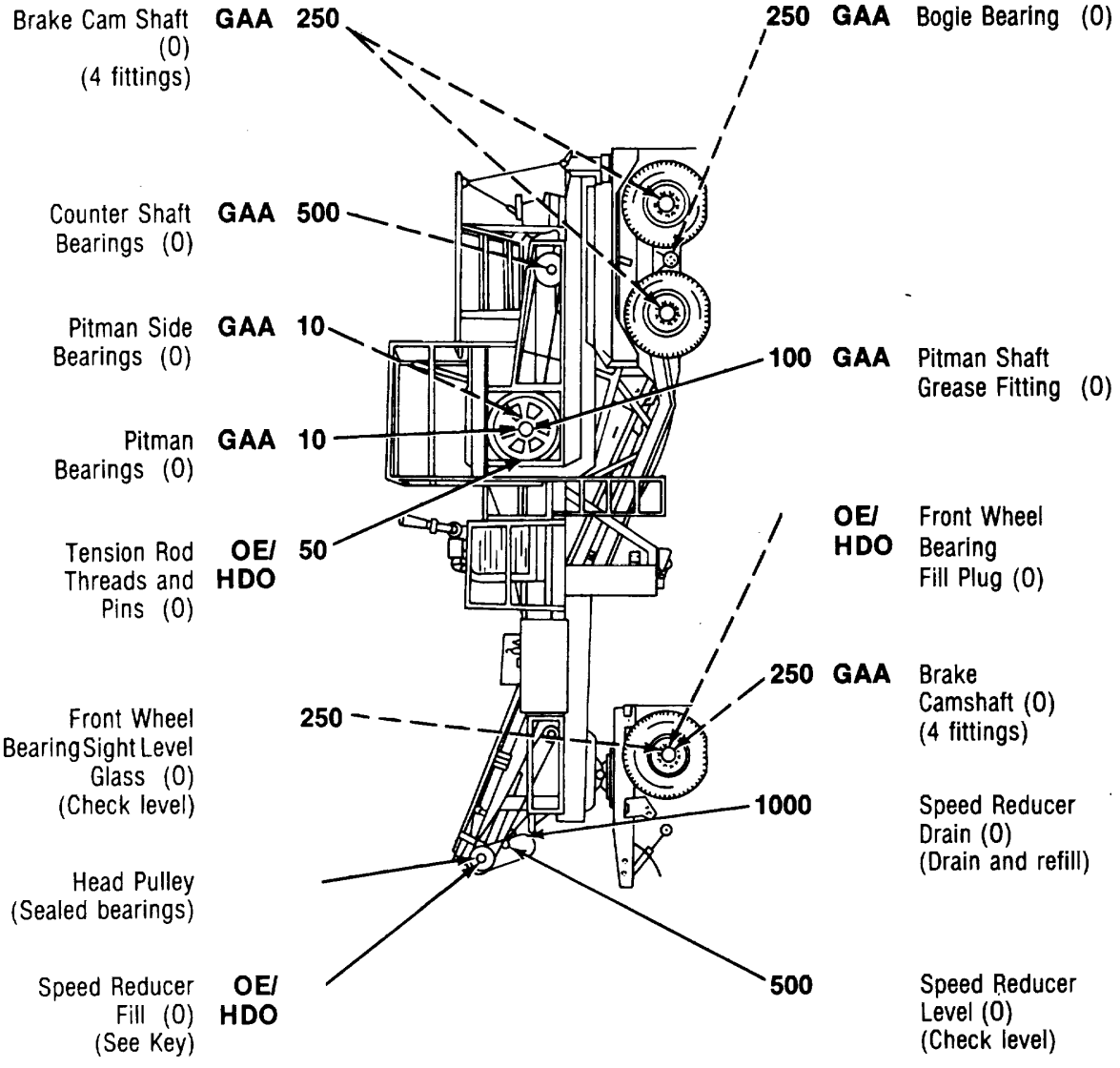

RIGHT SIDE

LUBRICANT • INTERVAL

INTERVAL • LUBRICANT

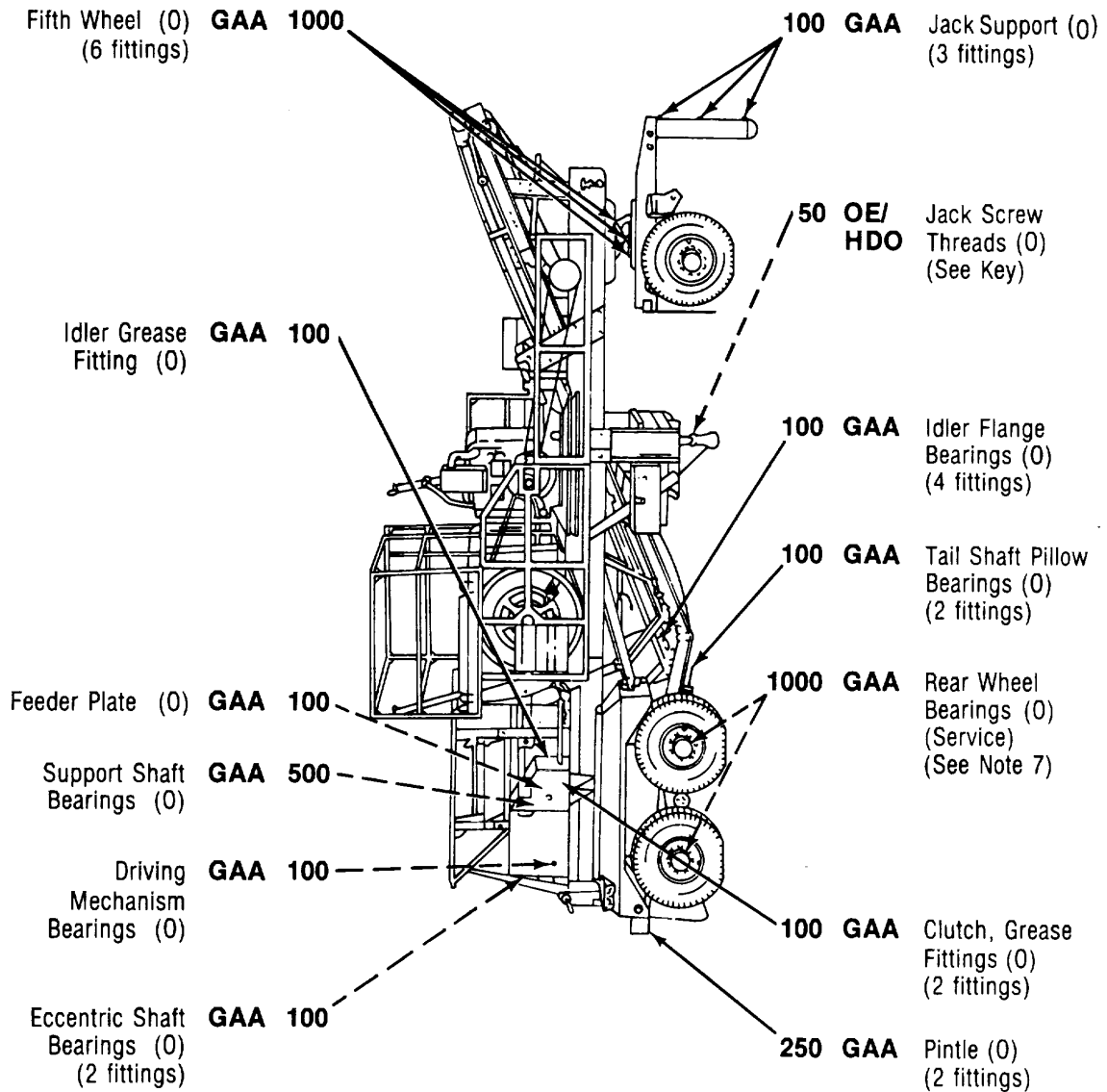

LEFT SIDE

- KEY -

LUBRICANTS	CAPACITY	EXPECTED TEMPERATURES			INTERVALS
		Above +15°F (Above -9°C)	+40° to -15°F (+4° to -26°C)	+40° to -65°F (+4° to -54°C)	
OE/ HDO - Lubricating Oil, Internal Combustion Engine, Tactical Service OEA - Lubricating Oil, Internal Combustion, Arctic - Oil Can Points (See Note 3) - Crankcase - Speed Reducer	19 qt. (18 L)	OE/HDO 30	OE/HDO 10	OEA (See Note 2)	OC - On Condition (AOAP) Intervals given are in hours of normal operation.
GAA - Grease, Automotive and Artillery		ALL TEMPERATURES			

For Arctic operation refer to FM 9-207

*See Note 8 for lubricant specification number.

1. ARMY OIL ANALYSIS PROGRAM (AOAP). For Active Army units, obtain samples from engine and automatic transmission every 50 hours of operation or 60 days (whichever comes first). Reserve and National Guard activities will use 50 hours or 120 days as the prescribed sample intervals. Reserve and National Guard equipment in frequent use during active training period will adhere to the schedule for Active Army units. As a minimum, one sample from each units' two week active training period will be submitted for each item of equipment. Send these samples to the nearest AOAP laboratory. Refer to TB 43-0210 for sampling instructions. When or if AOAP laboratory support is unavailable, hard time Intervals will apply.

NOTE

Do not hold oil samples. Submit oil samples as soon as they have been taken.

*Seasonal oil changes will be made due to expected temperatures. (See Key.)

2. FOR OPERATION OF EQUIPMENT IN PROTRACTED COLD TEMPERATURES BELOW -150F (-260C). Remove lubricants prescribed in Key for temperatures above -150F (-260C). Relubricate with lubricants specified in Key for temperatures below -150F (-260C). If OEA lubricant is required to meet the temperature ranges prescribed in the Key, OEA lubricant is to be used in place of OE/HDO-10 lubricant for all temperature ranges where OE/HDO-10 is specified in the Key.

3. OIL CAN POINTS. Each 50 hours lubricate control linkage, pins and clevises, and all exposed adjusting threads with OE/HDO.

4. ENGINE OIL LEVEL HOT OR COLD CHECK. Cold engine, oil level should be

NOTES - CONTINUED:

at high mark on dipstick. Hot engine, oil level must be between high and low marks on dipstick (allow to set 5 minutes before checking).

5. ENGINE. Oil is to be changed each time an engine oil change is directed by AOAP laboratory. When AOAP laboratory support is not available, change oil each 100 hours. Drain when oil is warm.

6. ENGINE OIL FILTER. Filter is to be replaced each time an engine oil change is directed by AOAP laboratory. After installing new filter element, fill crankcase, operate engine 5 minutes, check housing

for leaks, check crankcase oil level and bring to full mark. When AOAP laboratory support is not available, install new filter element each 100 hours.

7. REAR WHEEL BEARINGS. Each 1000 hours, remove wheels, clean and inspect all parts, replace worn or damaged parts, repack bearings, and reassemble.

8. LUBRICANTS. The following is a list of lubricants with military symbols and applicable specification numbers.

OE/HDO	MIL-L-2104
GAA	MIL-G-10924
OEA	MIL-L-46167
(SD), Type II	P-D-680

Copy of this Lubrication Order will remain with the equipment at all times, instructions contained herein are mandatory. By order of the Secretary of the Army:

JOHN A. WICKHAM, JR.
General, United States Army
Chief of Staff

OFFICIAL:

ROBERT M. JOYCE
Major General, United States Army
The Adjutant General

DISTRIBUTION:

To be distributed in accordance with DA Form 12-25B, Operator and Organizational maintenance requirements for Crushing and Screening Plants.

TA 220083

LO 5-3820-233-12-1

RECOMMENDED CHANGES TO EQUIPMENT TECHNICAL PUBLICATIONS



THEN... JOT DOWN THE DOPE ABOUT IT ON THIS FORM, CAREFULLY TEAR IT OUT, FOLD IT AND DROP IT IN THE MAIL!

SOMETHING WRONG WITH THIS PUBLICATION?

FROM: (PRINT YOUR UNIT'S COMPLETE ADDRESS)

DATE SENT

PUBLICATION NUMBER

PUBLICATION DATE

PUBLICATION TITLE

BE EXACT... PIN-POINT WHERE IT IS

PAGE NO.

PARA-GRAPH

FIGURE NO.

TABLE NO.

IN THIS SPACE TELL WHAT IS WRONG AND WHAT SHOULD BE DONE ABOUT IT:

TEAR ALONG PERFORATED LINE

PRINTED NAME, GRADE OR TITLE, AND TELEPHONE NUMBER

SIGN HERE:

DA FORM 2028-2
1 JUL 79

PREVIOUS EDITIONS ARE OBSOLETE.

P.S.—IF YOUR OUTFIT WANTS TO KNOW ABOUT YOUR RECOMMENDATION MAKE A CARBON COPY OF THIS AND GIVE IT TO YOUR HEADQUARTERS.

THE METRIC SYSTEM AND EQUIVALENTS

WEIGHT MEASURE

1 Centimeter = 10 Millimeters = 0.01 Meters = 0.3937 Inches
 1 Meter = 100 Centimeters = 1000 Millimeters = 39.37 Inches
 1 Kilometer = 1000 Meters = 0.621 Miles

WEIGHTS

1 Gram = 0.001 Kilograms = 1000 Milligrams = 0.035 Ounces
 1 Kilogram = 1000 Grams = 2.2 lb.
 1 Metric Ton = 1000 Kilograms = 1 Megagram = 1.1 Short Tons

LIQUID MEASURE

1 Milliliter = 0.001 Liters = 0.0338 Fluid Ounces
 1 Liter = 1000 Milliliters = 33.82 Fluid Ounces

SQUARE MEASURE

1 Sq. Centimeter = 100 Sq. Millimeters = 0.155 Sq. Inches
 1 Sq. Meter = 10,000 Sq. Centimeters = 10.76 Sq. Feet
 1 Sq. Kilometer = 1,000,000 Sq. Meters = 0.386 Sq. Miles

CUBIC MEASURE

1 Cu. Centimeter = 1000 Cu. Millimeters = 0.06 Cu. Inches
 1 Cu. Meter = 1,000,000 Cu. Centimeters = 35.31 Cu. Feet

TEMPERATURE

$5/9(^{\circ}\text{F} - 32) = ^{\circ}\text{C}$
 212° Fahrenheit is equivalent to 100° Celsius
 90° Fahrenheit is equivalent to 32.2° Celsius
 32° Fahrenheit is equivalent to 0° Celsius
 $9/5^{\circ}\text{C} + 32 = ^{\circ}\text{F}$

APPROXIMATE CONVERSION FACTORS

TO CHANGE	TO	MULTIPLY BY
Inches	Centimeters	2.540
Feet	Meters	0.305
Yards	Meters	0.914
Miles	Kilometers	1.609
Square Inches	Square Centimeters	6.451
Square Feet	Square Meters	0.093
Square Yards	Square Meters	0.836
Square Miles	Square Kilometers	2.590
Acres	Square Hectometers	0.405
Cubic Feet	Cubic Meters	0.028
Cubic Yards	Cubic Meters	0.765
Fluid Ounces	Milliliters	29.573
its	Liters	0.473
arts	Liters	0.946
allons	Liters	3.785
Ounces	Grams	28.349
Pounds	Kilograms	0.454
Short Tons	Metric Tons	0.907
Pound-Feet	Newton-Meters	1.356
Pounds per Square Inch	Kilopascals	6.895
Miles per Gallon	Kilometers per Liter	0.425
Miles per Hour	Kilometers per Hour	1.609

TO CHANGE	TO	MULTIPLY BY
Centimeters	Inches	0.394
Meters	Feet	3.280
Meters	Yards	1.094
Kilometers	Miles	0.621
Square Centimeters	Square Inches	0.155
Square Meters	Square Feet	10.764
Square Meters	Square Yards	1.196
Square Kilometers	Square Miles	0.386
Square Hectometers	Acres	2.471
Cubic Meters	Cubic Feet	35.315
Cubic Meters	Cubic Yards	1.308
Milliliters	Fluid Ounces	0.034
Liters	Pints	2.113
Liters	Quarts	1.057
ers	Gallons	0.264
ms	Ounces	0.035
ograms	Pounds	2.205
Metric Tons	Short Tons	1.102
Newton-Meters	Pounds-Feet	0.738
Kilopascals	Pounds per Square Inch	0.145
ometers per Liter	Miles per Gallon	2.354
ometers per Hour	Miles per Hour	0.621

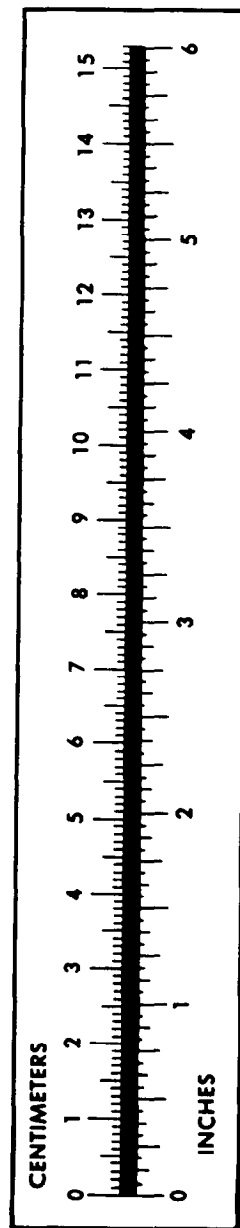

PIN: 055016-000